



Air Springs - inspection & troubleshooting guide

The information below is designed to help when servicing your air springs.

Routine inspection

- Check all air lines for leaks.
- Check air springs have enough clearance when inflated.
Mis-aligned suspension parts rubbing on the air spring will cause the diaphragm or bellow to wear away.
- Check the original specification for the suspension's ride height as in fig 1.
This should be maintained to protect the air springs and shock absorbers from over extension.
- Check the diaphragm or bellow for irregular wear, natural wear or outside interference.
- Clean the diaphragm or bellow with a non-petroleum based solution.
- Check the piston, on rolling lobe type air springs, for sharp edges or settlement of dirt or foreign bodies.
- Check shock absorbers for over extension, bush wear and fluid loss.
If the unit can be easily compressed or extended it will not function correctly.
If the vehicle has recently been in use the shock absorber should be warm to the touch, if this is not the case, the unit may need to be replaced.
- Check all torque settings are correct to original specification.
- Check height control valve function.
- Mounting fixing bolts and nuts should be replaced every time.

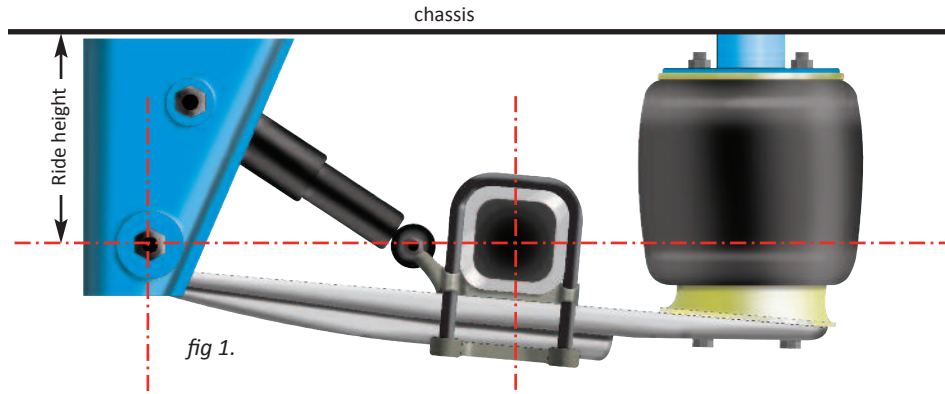

Air springs - troubleshooting

The information below is designed to help when determining the cause of air spring failure.

The vast majority of premature failures and consequent warranty returns are found not to be caused by faulty products, but are caused by a lack of suspension maintenance, incorrect installation or other associated problems.

Before installing a new air spring, it is recommended to carefully examine the cause of the failure. If the cause is not rectified, this will result in the failure of the newly installed air spring.

The information below is a guide to the most common air spring failures and are NOT COVERED BY WARRANTY.

Loose girdle hoop



Appearance

- Rubber bellows distorted.
- Girdle hoop torn loose.

Possible Cause

- Running at extended positions with low air pressure.

Circumferential abrasion



Appearance

- Hole in diaphragm or bellow below bead plate.

Possible Cause

- Misaligned bump stop.
- worn suspension bushes.
- incorrect installation.



Never attempt to service the air suspension while the air spring is inflated.



The names and numbers of third party manufacturers are used to identify the equivalent Juratek product and such use does not imply any connection with such manufacturers.



Chafing between bead plate and bellow

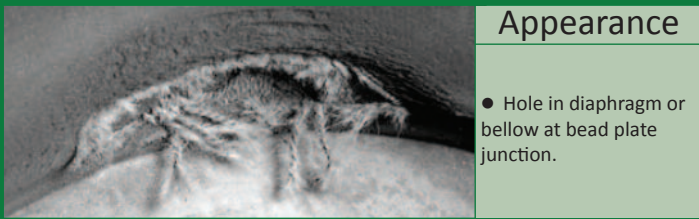

Appearance

- Hole in diaphragm or bellow at bead plate junction.

Possible cause

- Misaligned bump stop.
- Worn suspension bushes.
- Incorrect installation.

Bottoming out

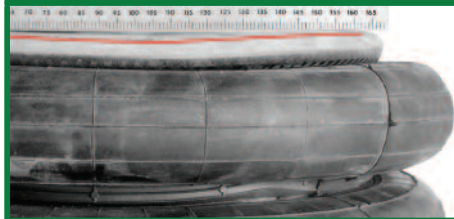

Appearance

- Bead plate concave (see red line).
- Internal bumper loose.
- Hole in girdle hoop area.

Possible cause

- Broken or defective shock absorber.
- Defective levelling valve.
- Overloaded vehicle.
- Pressure regulator set too low.
- Incorrect air spring fitted.

Abrasion

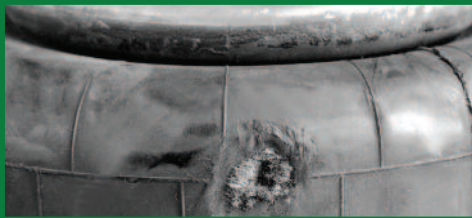

Appearance

- Hole rubbed into side of bellow/ diaphragm.

Possible cause

- Structural interference (broken shock absorber, loose air line, misalignment, worn bushes).
- No air pressure (rolling lobe type).
- Foreign material.
- Incorrect air spring fitted.

Circumferential cuts

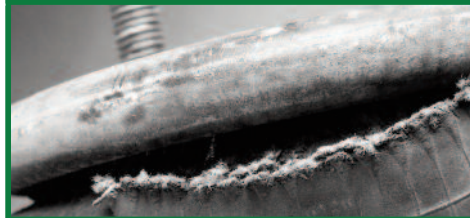

Appearance

- Bellows cut along bead plate junction.
- Bellows cut along piston junction.

Possible cause

- Running at full extension with high air pressure for long periods of time.
- Impact in compressed position.

Over extension

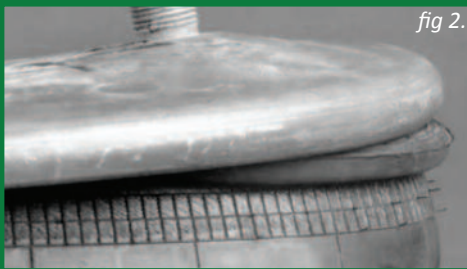

fig 2.

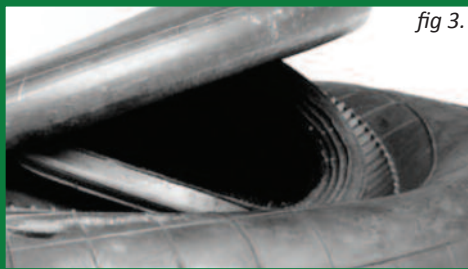

fig 3.

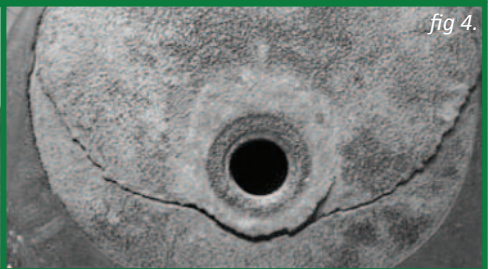

fig 4.

Appearance

- Bead plate convex, especially around blind nuts or studs (fig 2.).
- Rubber bellows separated from bead plate (fig 3.).
- Leaking at blind nuts or studs (fig 4.).
- Leaking at end closure (fig 4.).
- Loose girdle hoop on convoluted style.

Possible cause

- Broken shock absorber.
- Incorrect shock absorber fitted.
- Defective levelling valve.
- Ride position set too high.
- Incorrect air spring fitted.

Preventative maintenance - listed below are items that can be checked when the vehicle is in for periodic maintenance.

1. Inspect the outer diameter of the air spring. Check for signs of irregular wear or heat cracking.
2. Inspect air lines to make sure contact doesn't exist between the air line and the outer diameter of the air spring. Air lines can rub a hole in the air spring bellow.
3. Check to see that there is sufficient clearance around the complete circumference of the air spring while at it's maximum diameter.
4. Inspect the outer diameter of the piston for build up of foreign materials. (On a reversible sleeve style air spring, the piston is the bottom component of the air spring).
5. Correct ride height should be maintained. All vehicles with air springs have a specified ride height established by the OE manufacturer. This height, which is found in your service manual, should be maintained within 1/4 inch. This dimension can be checked with the vehicle loaded or empty.
6. Levelling valves (height control valves) play a large part in ensuring that the total air spring system works as required. Clean, inspect and replace if necessary.
7. Make sure you have the correct shock absorbers and check for leaking hydraulic oil and worn or broken end connectors. If a broken shock absorber is found, replace it immediately. The shock absorber will normally limit the rebound of an air spring and prevent it over extending.
8. Check the tightness of all mounting hardware (nuts and bolts). If loose retorque to the OE manufacturer's specifications. Do not over tighten.
9. When cleaning use only approved cleaning methods. (these include; soap, water, methyl alcohol, ethyl alcohol and isopropyl alcohol).

The names and numbers of third party manufacturers are used to identify the equivalent Juratek product and such use does not imply any connection with such manufacturers.

