



From the track...

**JURATEK®**

...to the road

**Design Enhancement**

*Splined Disc With Intermediate Elements*

**DAF111/B**

**DAF:** XF95 series, CF65 series, CF75 series, CF85 series **FODEN:** Alpha series  
Equivalent to: DAF111, DAF111/A, Z0009911, K004322, ii39112F, ii39541F, 1387349, 1640561

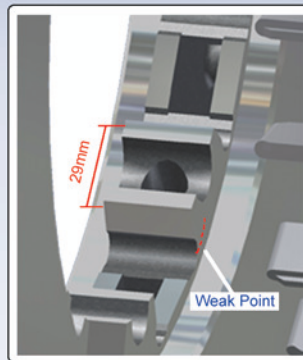
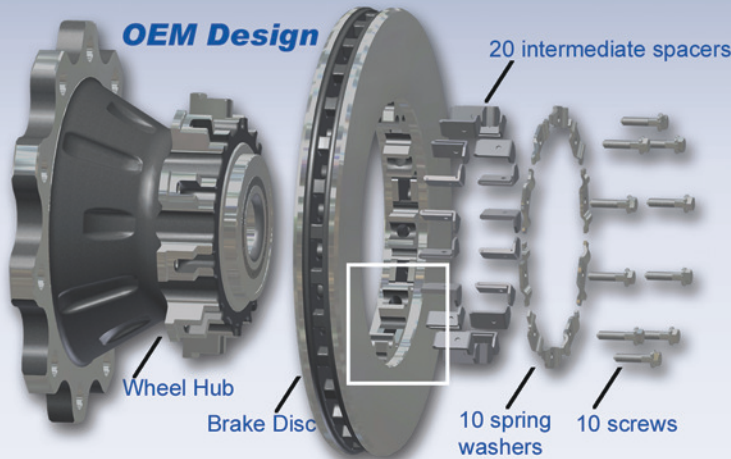

This new design reduces the fitting and removal times due to the simpler fitting elements and increases the strength of the fitting.

The original design has 20 intermediate spacers that can be difficult to install and even more difficult to remove.

Juratek have increased the size of the intermediate splines and replaced the 10 spring washers with one single fixing ring.

This new design also gives added strength to the intermediate splines. This increased strength comes from the intermediate splines being increased in width and the centre gap being filled.

This can prevent the splines from separating from the disc when under stress.

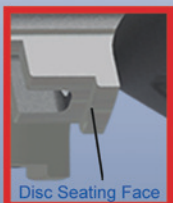
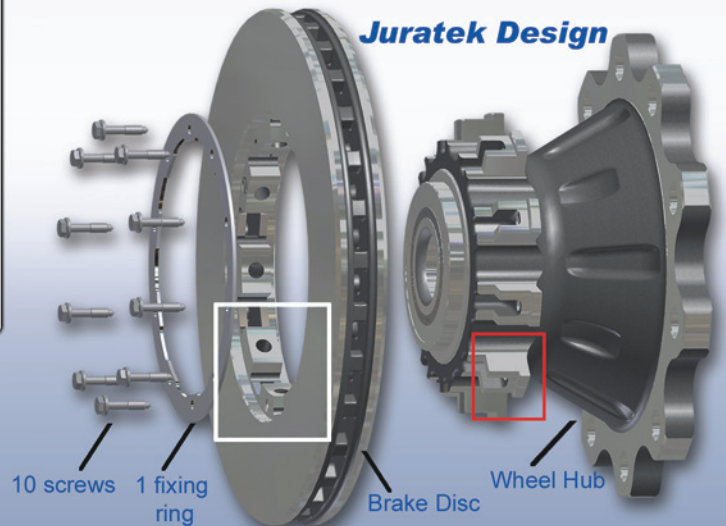
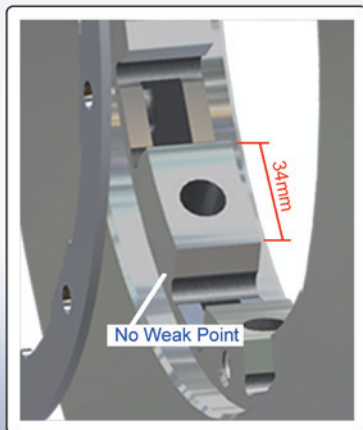

A further development has been made to allow for additional wear of the hub seating face. This now allows up to 1.5mm of wear to the seating face, by which time the hub should be replaced.

[www.juratek.com](http://www.juratek.com)

